

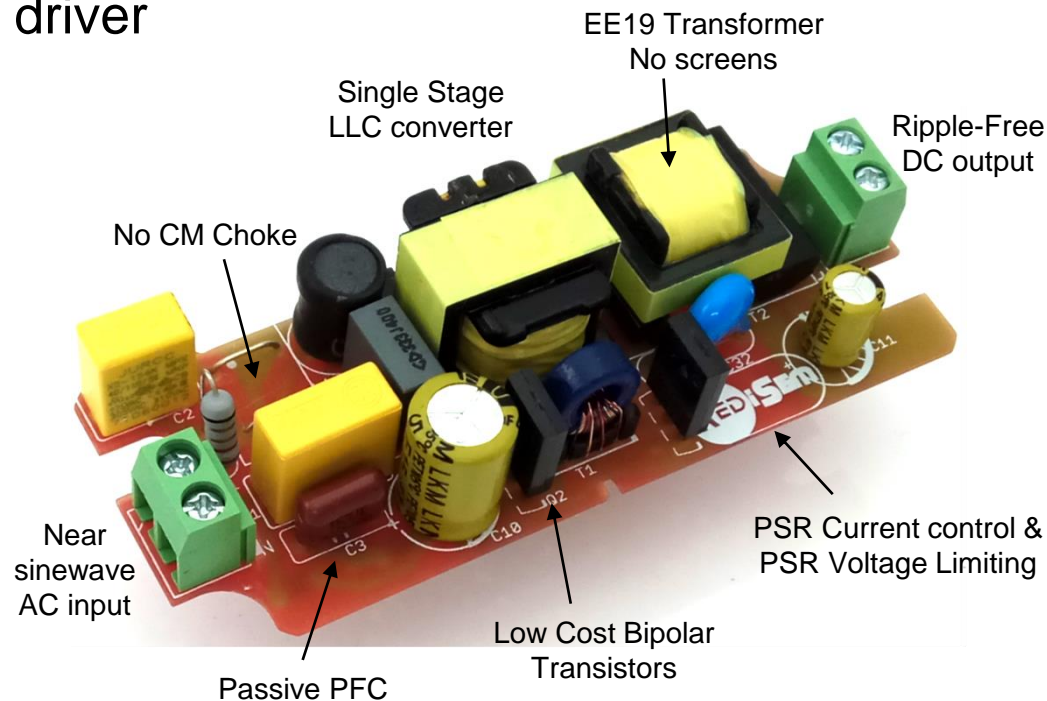

40W LED Driver Design Report

May 2017

- Low-cost Flicker-free CC LED driver
- Efficiency 90.7%
- High Power Factor >0.9
- 1.0A 32-40V output
- Low EMI – no CM choke
- Optimized for COB/Panel



Specifications



Specification	Value	Test condition
Input voltage 50Hz	198 - 264VAC	Functional specifications
Input functional range	170 - 320VAC	5 minute survival
Output voltage	32 - 40V	198 - 264VAC
Output current	1A \pm 5%	198 - 264VAC
LF Ripple (Flicker)	<2% - see page 18	230VAC, 40VDC
Harmonic compliance IEC 61000-3-2	220 - 240VAC	32-39V DC
Total Ripple	< 20%	230VAC, 40VDC
Time to light	< 200ms	230VAC, 40VDC
Efficiency	> 90%	230VAC, 40VDC
Power factor	> 0.97	230VAC, 40VDC
THD	< 10%	230VAC, 40VDC
No-load voltage	< 60V	264VAC
Protection	Overtemperature, short circuit, open circuit	
EMI test	6dB margin	LED earthed, Driver floating
Surge	1kV DM , 2kV CM	
Ambient Temperature	-20 to 50°C	

Schematic

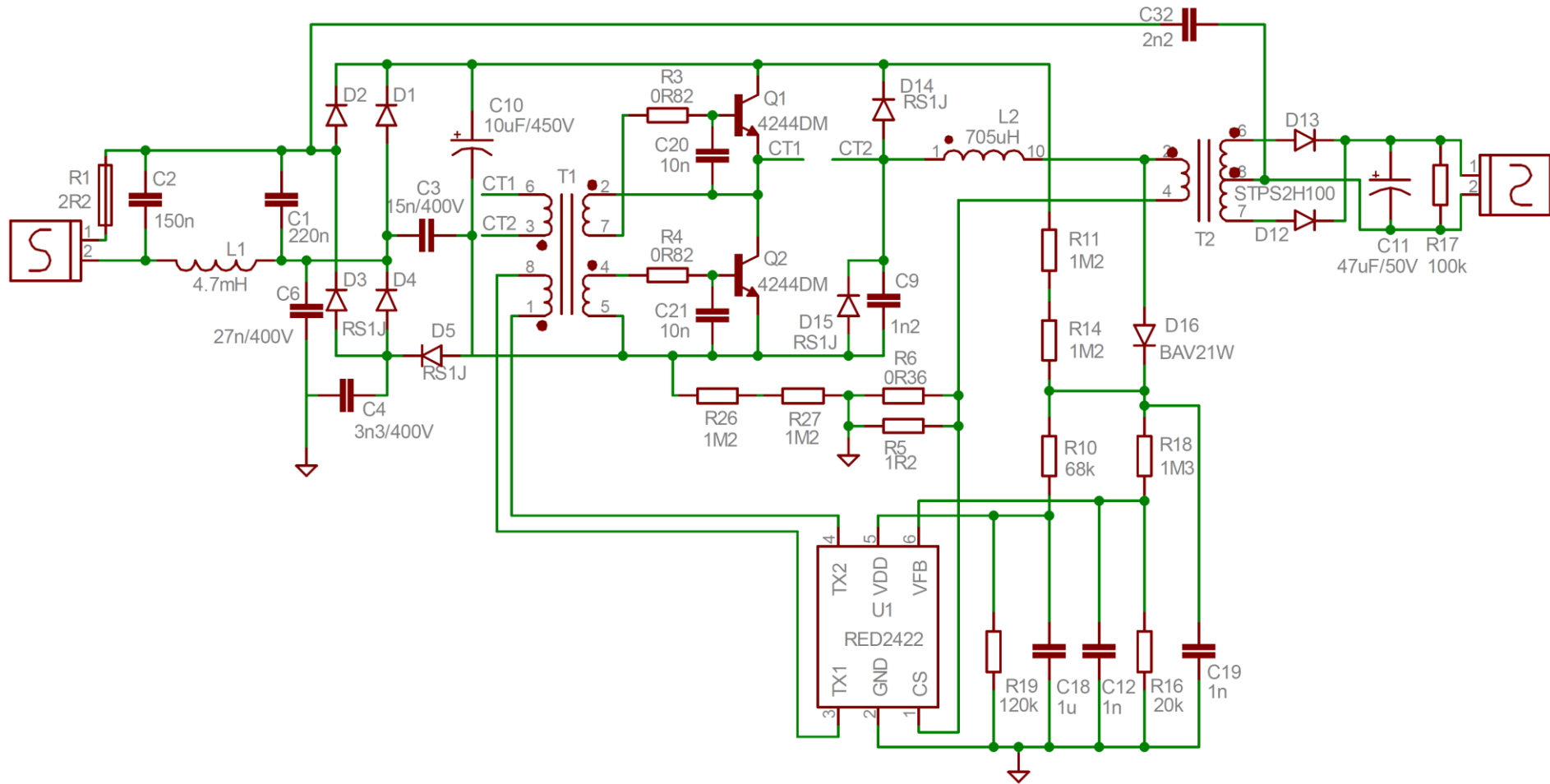

Code	Value	Description	Qty
C1	220n	X2 MKP 20% 275VAC	1
C2	150n	X2 MKP 20% 275VAC	1
C3	15n	MKP 5% 400VDC	1
C4	3n3	1206 NPO 5% 500VDC	1
C6	27n	MKP 5% 400VDC	1
C9	1n2	1206 NPO 5% 500VDC	1
C10	10u	ELEC 20% 450VDC	1
C11	47u	ELEC 20% 50VDC	1
C12	1n	0805 X7R 10% 50VDC	1
C19	1n	0805 X7R 10% 100VDC	1
C18	1u	0805 X7R 10% 16VDC	1
C20 21	10n	0805 X7R 10% 16VDC	2
C32	2n2	Y-CAP	1
D1,2,3,4,5,14,15	RS1J	SMA Fast Diode 600VDC	7
D12,D13	STPS3H100	Schottky Diode, 100V 3A	2
D16	BAV21W	MiniMELF	1
L1	4m7H	8x10 Drum Core	1
L2	705uH	Main Inductor EE/19/16/10	1
R1	2R2	Fuse resistor 2R2	1
R3,4	0R82	0805 0.06W 1.0%	2
R5	1R2	1206 0.25W 1.0%	1
R6	0R36	1206 0.25W 1.0%	1
R7, 11, 26, 27	1M2	1206 0.25W 1.0%	4
R10	68k	0805 0.06W 1.0%	1
R16	20k	0805 0.06W 1.0%	1
R17	100k	1206 0.06W 1.0%	1
R18	1M3	0805 0.06W 1.0%	1
R19	120k	0805 0.06W 1.0%	1
P1,P2		Terminal 2 Pin	2
Q1,Q2	3DD4244DM	NPN (Ts=2-2.5us) TO126 3A	2
T1	T9x5x4	Base Drive: 18:6:6:1 turns	1
T2	EE19	Output Transformer	1
U1	RED2422	Low Ripple LED controller IC	1
TOTAL			47

PCB layout

Top Side

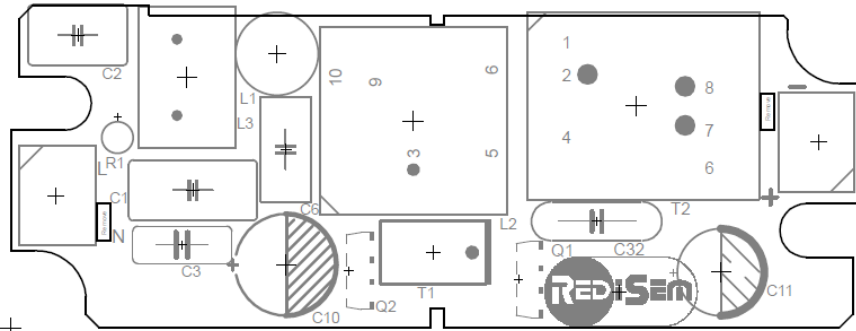

Bottom Side

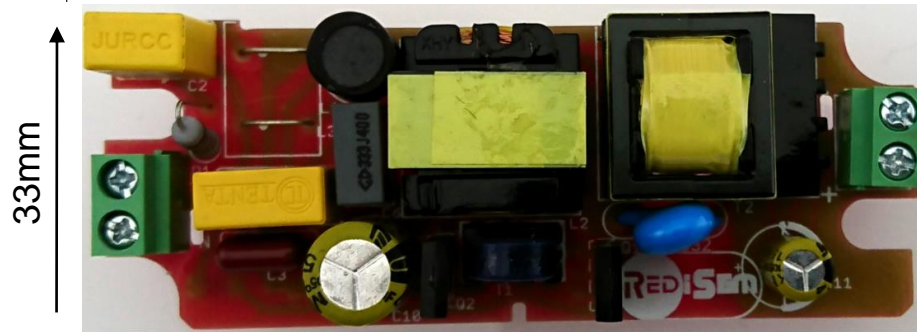
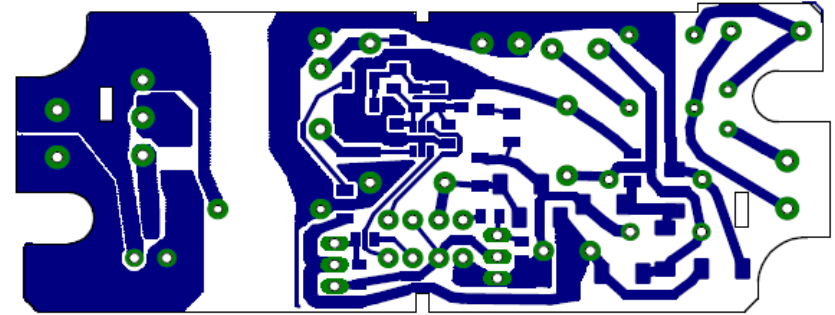

33mm

87mm

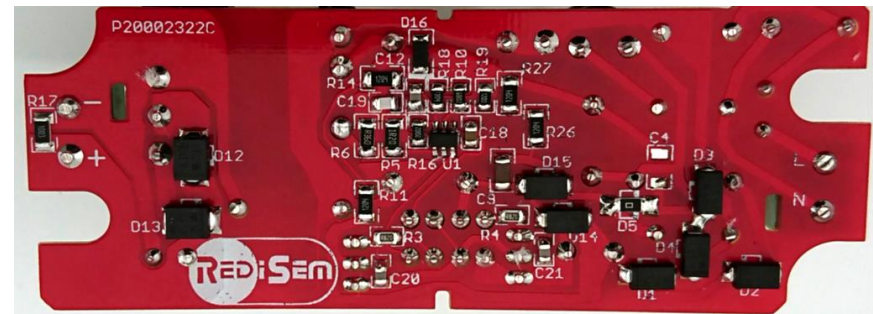
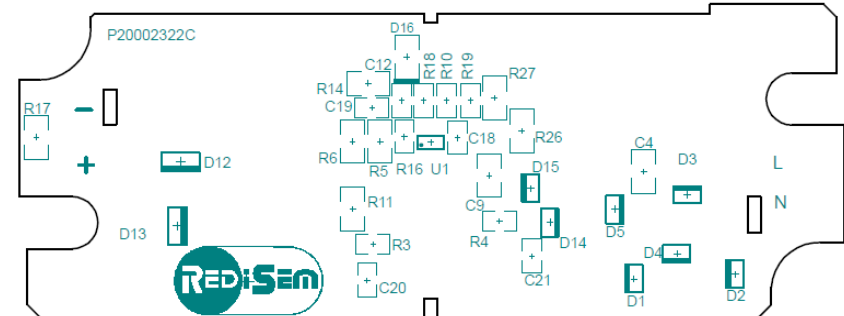

- Single sided PCB
- 1mm thick
- 1 Oz copper

Transformer Construction



Transformer	
Core type	EE19 PC47
Bobbin Type	EE19 SELV 5+4
Pri	51t x1s x 0.32mm ECW
Pri Inductance	3.4mH ±25%
Sec1&2	29t x 1s x 0.35mm TEXE

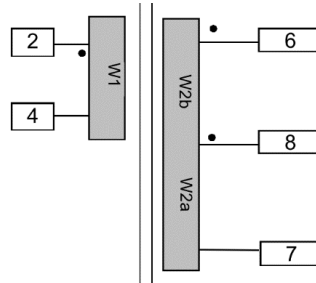

Winding	Turns	Start Pin	End Pin	Wire	Layers	Type	Purpose
W1	51	2	4	0.32mm	2	ECW	Primary
Tape	1						
W2a	29	6	8	0.35mm	2	TEXE	Secondary
W2b	29	8	7	0.35mm	2	TEXE	Secondary
Tape	1						

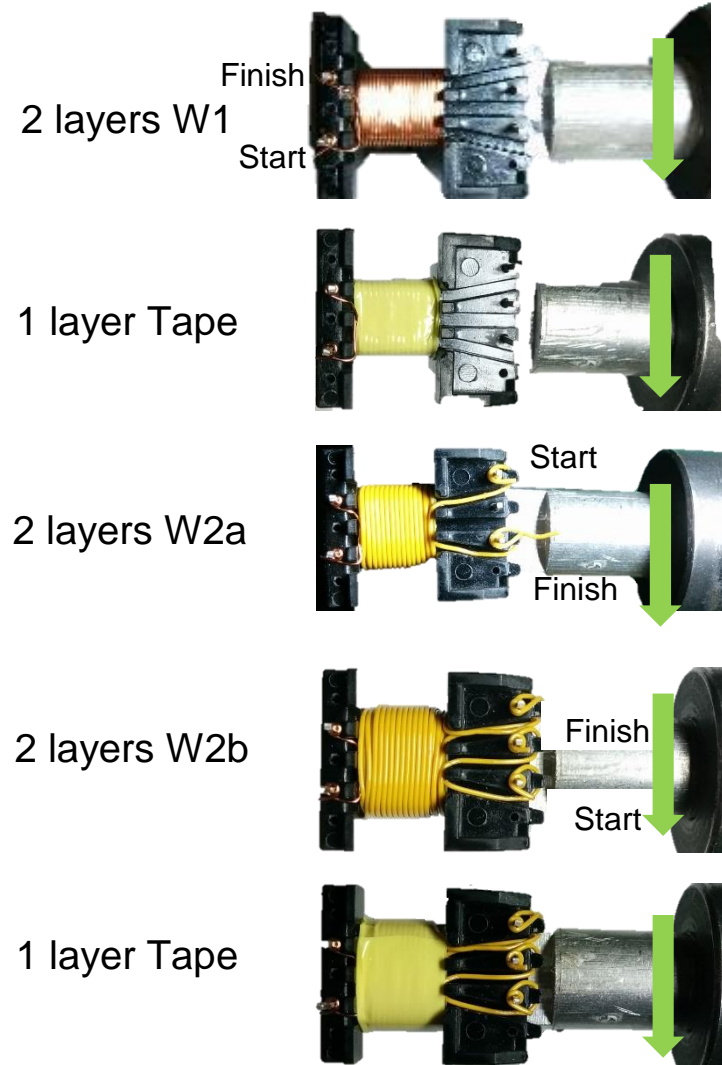
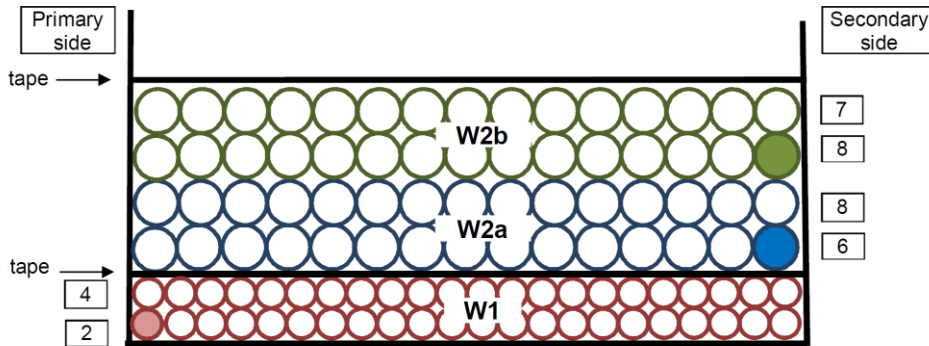

Test Results



Output Voltage	32V					40V				
	198V	215V	230V	245V	264V	198V	215V	230V	245V	264V
Input voltage										
Output current	990mA	991mA	992mA	992mA	992mA	991mA	993mA	994mA	995mA	995mA
Input Power	35.42	35.49	35.54	35.58	35.66	43.72	43.73	43.82	44.05	44.17
Output Power	31.68	31.71	31.73	31.74	31.74	39.64	39.72	39.76	39.80	39.80
Efficiency	89.4%	89.4%	89.3%	89.2%	89.0%	90.7%	90.8%	90.7%	90.4%	90.1%
Power Factor	0.972	0.955	0.940	0.924	0.902	0.962	0.962	0.959	0.949	0.934
THD	10.0%	16.6%	22.2%	27.1%	32.4%	16.4%	15.2%	16.5%	19.4%	24.0%
Ripple (Flicker) @36V	1.60%	1.28%	1.11%	1.00%	0.90%					

Test	Result	Condition
Peak no-load Voltage	45.00V	230VAC
Time To light	140ms	230VAC

Harmonic	
Input Voltage	230Vac
Output Voltage	40V

Order	I1[A]	Hdf[%]
Total	200.23m	
1	198.29m	100.000
2	1.57m	0.791
3	21.77m	10.980
4	1.45m	0.731
5	10.13m	5.107
6	1.63m	0.821
7	9.88m	4.980
8	0.99m	0.500
9	4.11m	2.074
10	1.43m	0.723
11	3.35m	1.689
12	0.98m	0.494
13	4.26m	2.148
14	0.88m	0.446
15	4.22m	2.130

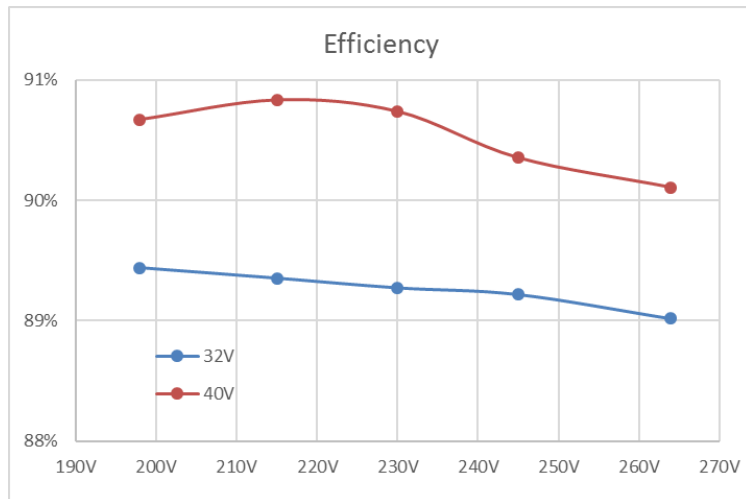

Test Results



Current Regulation

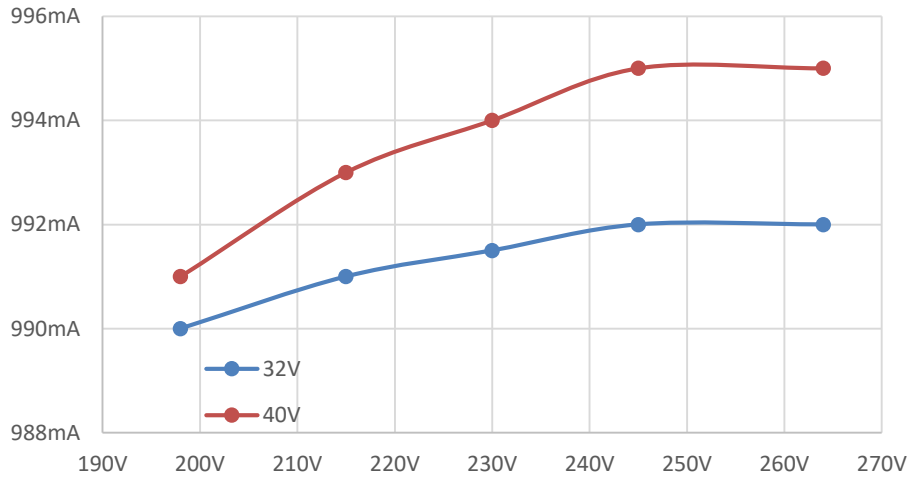

PF

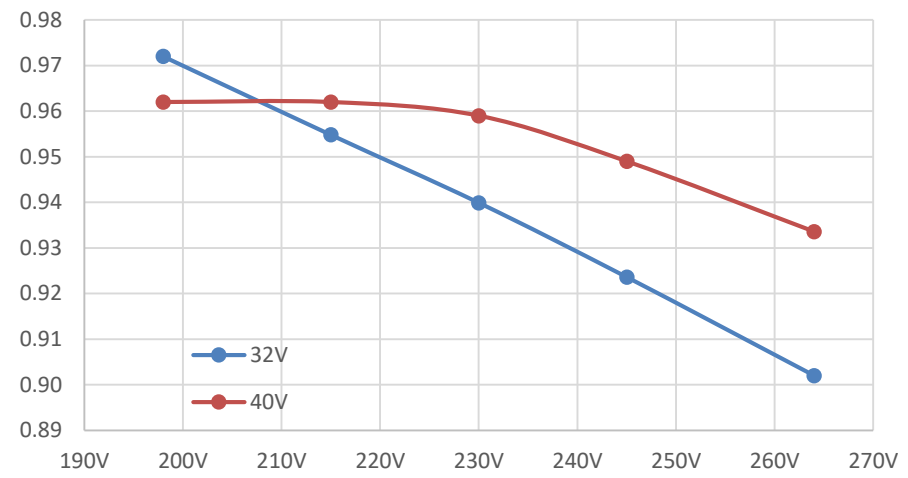

Flicker

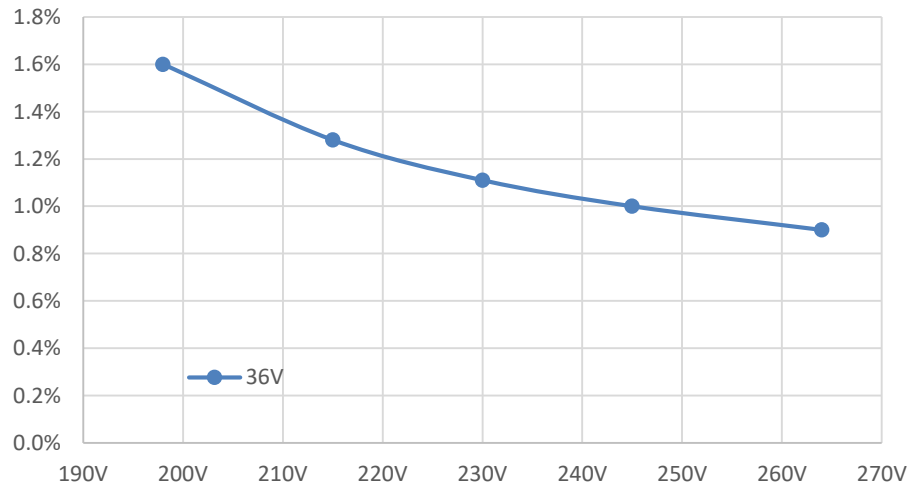

THD

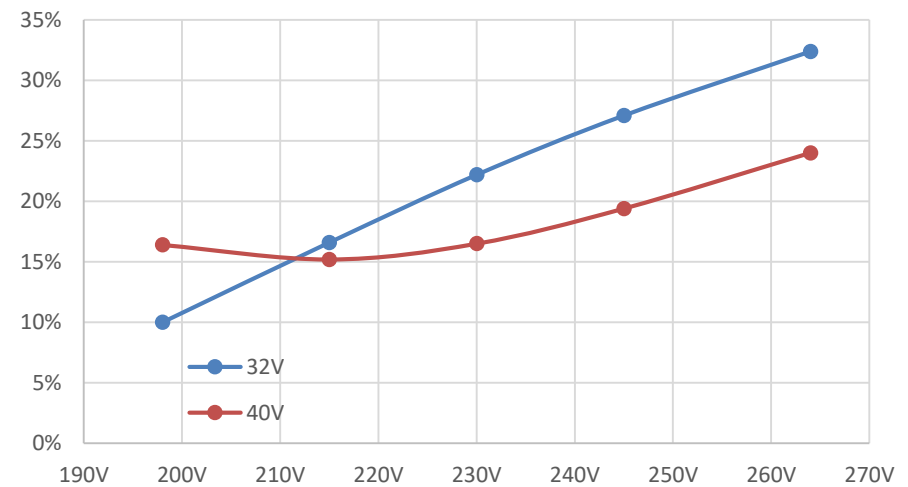

Test Results - Plots



Collector current and voltage

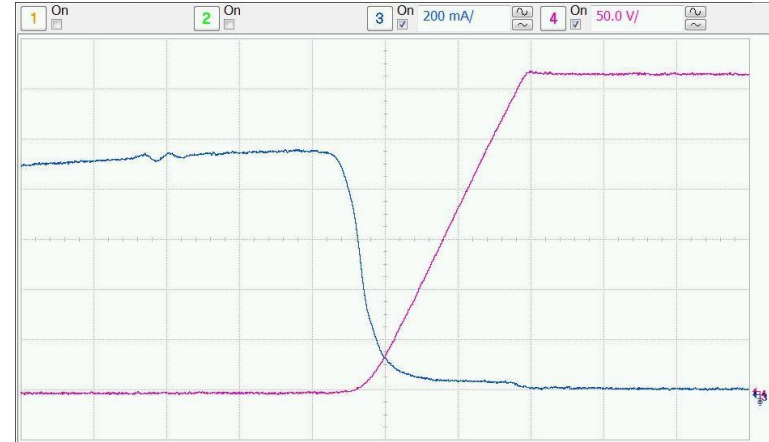

Resonant turn-off

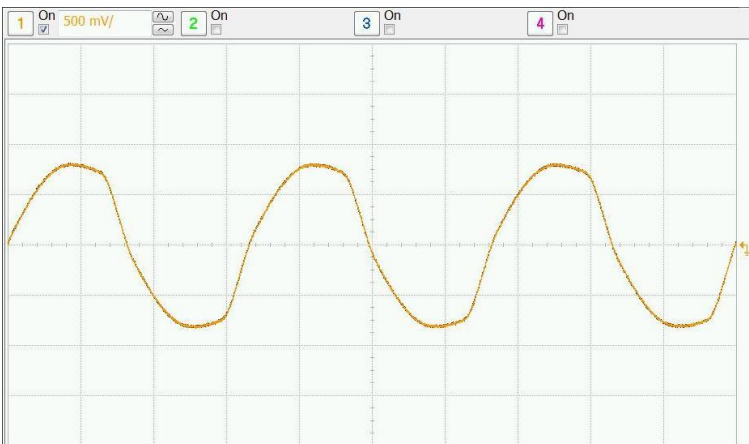

Inductor current 230VAC, 40VDC



Input current and output flicker current

Test Results - Plots

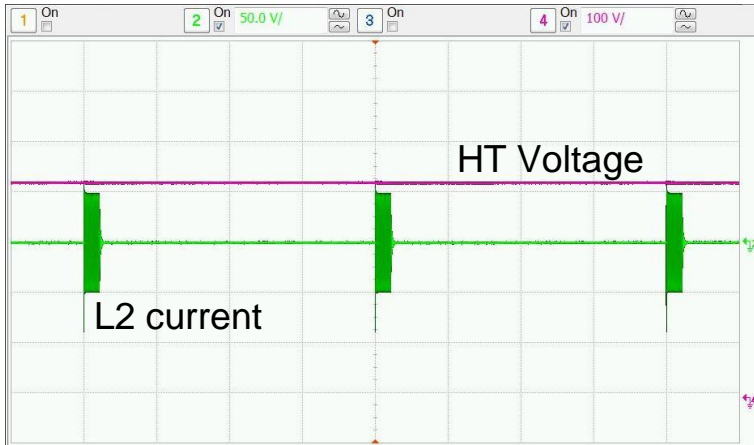

Short circuit protection 264VAC (Worst case)

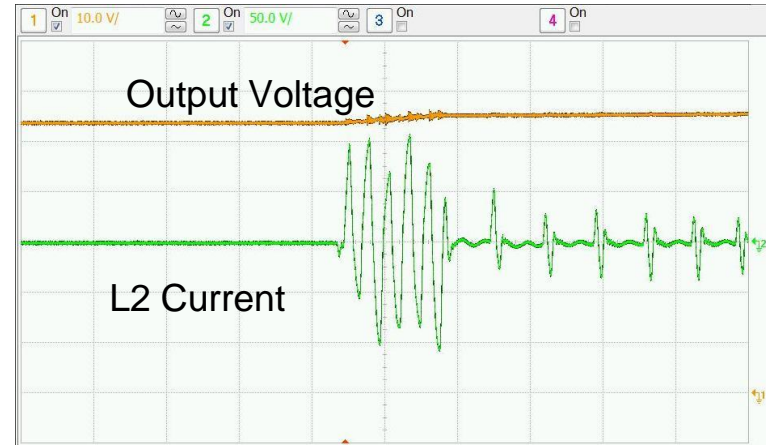

Open Circuit

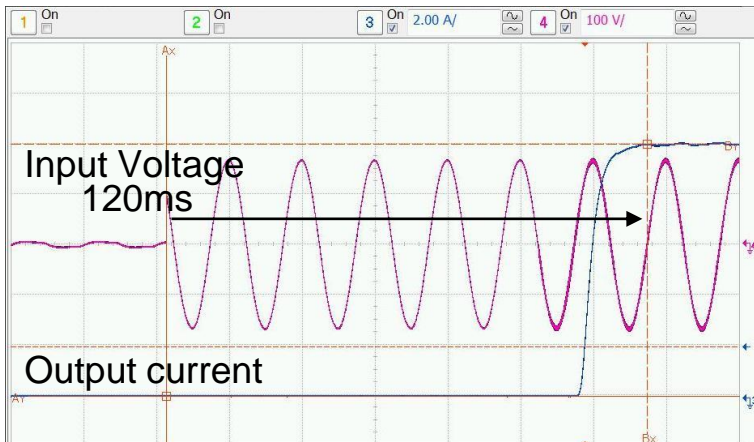

Time To light 230VAC, 40VDC

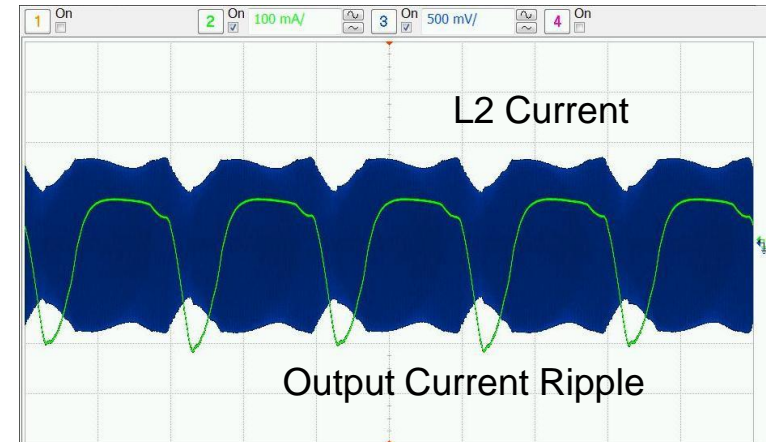

L2 current Capacitive mode operation - 180VAC, 40VDC

Test Results – EMI



Radiated Test Setup

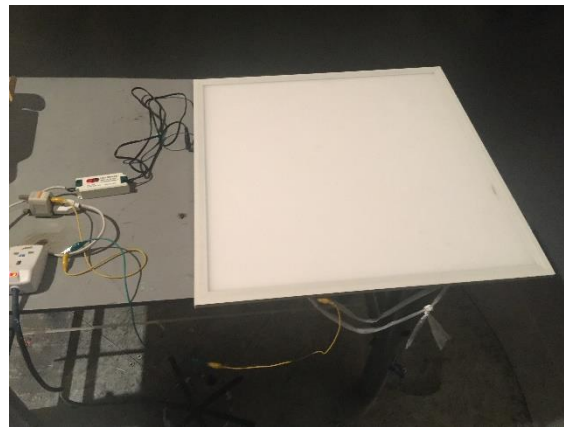

Conducted Test Setup



>10dB Margin EMI Pass

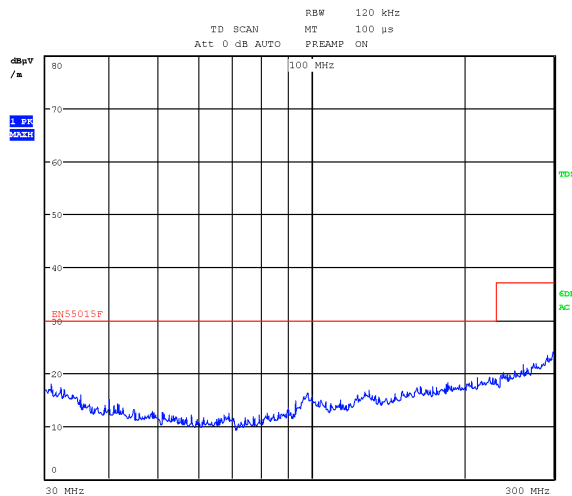

Radiated 30M~300MHz

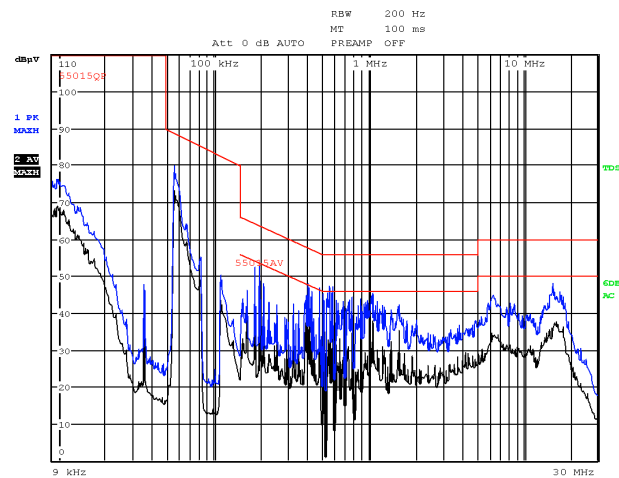

Conducted 9k~30MHz

Test Results - Surge

1kV surge pass with margin

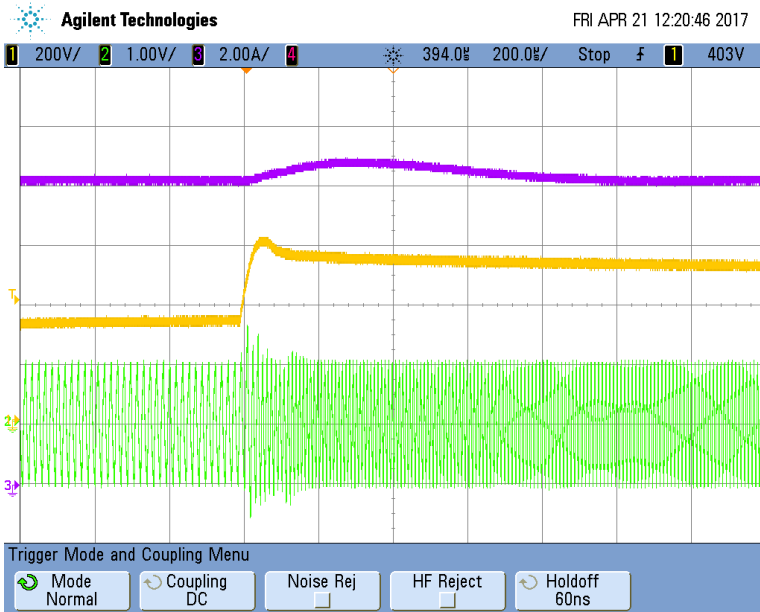

Plot of HT bus voltage and midpoint current during 1.2kV surge with fuse resistor

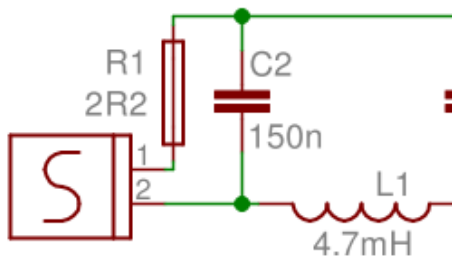

6kV surge upgrade with MOV

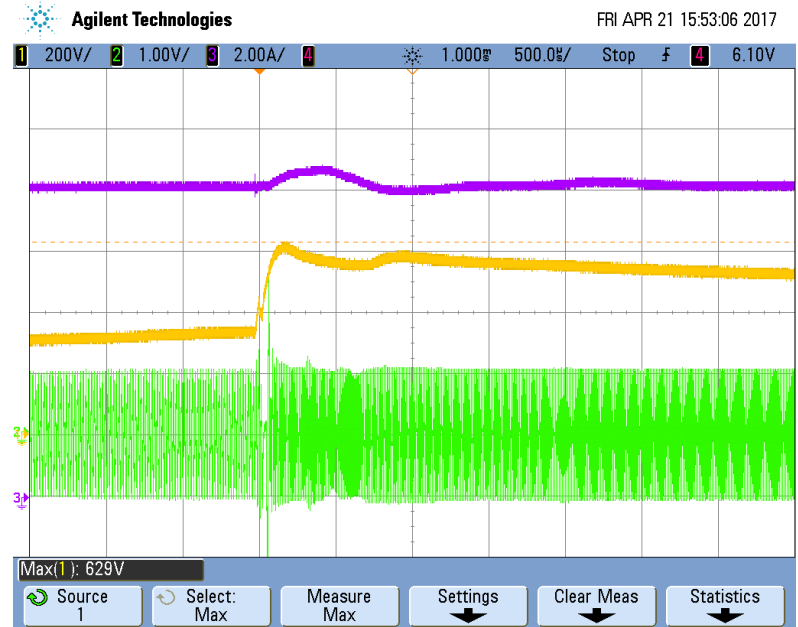

Plot of HT bus voltage and midpoint current during 6kV surge with Fuse and MOV

For 2kV to 6kV surge :

- Add MOV 14471
- Change Fuse-resistor to T-type, 2 to 6A

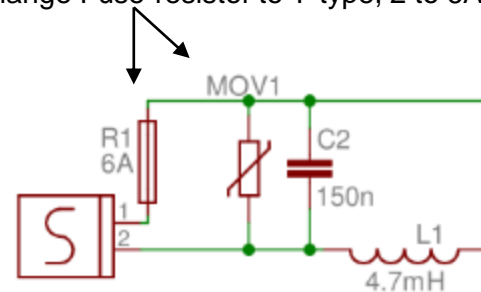

Test Results - Thermals



Test condition:

In a box in a heated oven
 $T_a = 50C$

Thermal Results (cased)	198V 40V	264V 32V
T_a	51.0C	51.0C
Q1	107.0C	117.0C
Q2	104.0C	117.0C
L2 core	100.0C	121.0C
L2 winding	100.0C	119.0C
T2 core	108.0C	117.0C
T2 winding	116.0C	109.0C



Test condition:

Open on the bench

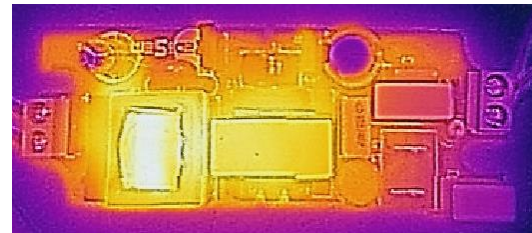

Top side Thermal

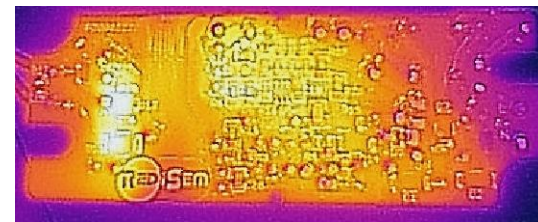

Bottom side Thermal

Test Results – AC transients



AC Mains transient 198Vac - 264Vac every 1second

Result: No flicker on LED

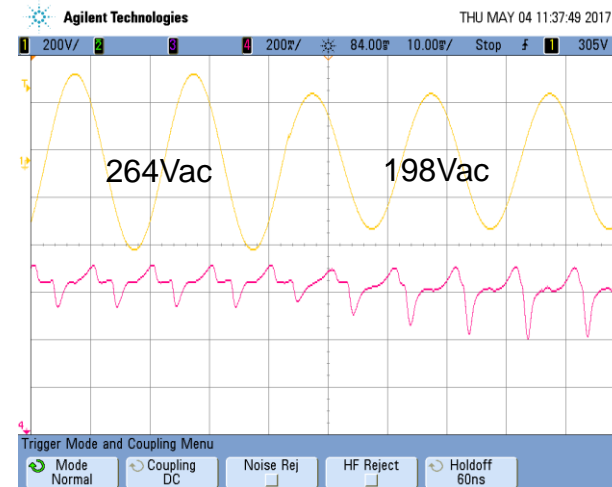
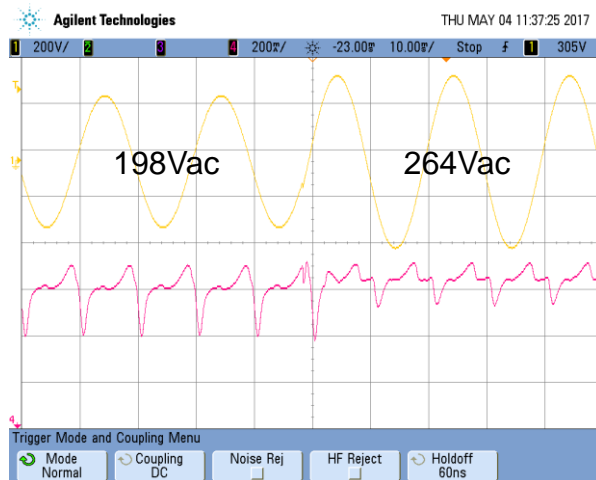
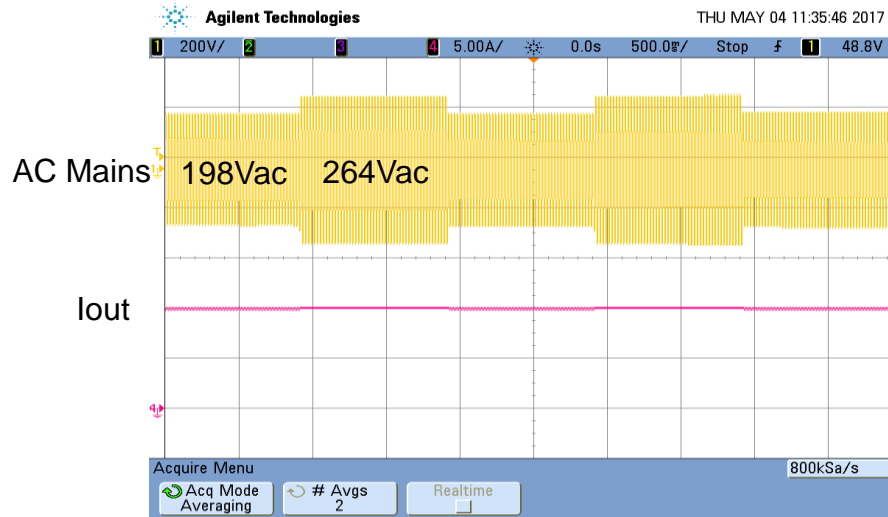

Upgrades – Better THD



Simple modifications for better THD –
Change the charge pump capacitors

Test unit	Harmonic Range	C3	C4	C6	THD at 36Voutput	VHT at 264Vac 32Voutput	Remarks
A (original)	Original	15n	3n3	27n	16.5%	398V	Optimized higher efficiency design
B	Better	15n	8n2	22n	12.2%	403V	Better THD, not much range improvement
C	Even better	15n	12n	22n	10.3%	407V	Better THD, wider range, less efficient, so hotter
D	Best	15n	15n	22n	8.8%	410V	Better THD, wider Range, even hotter, so consider larger case &

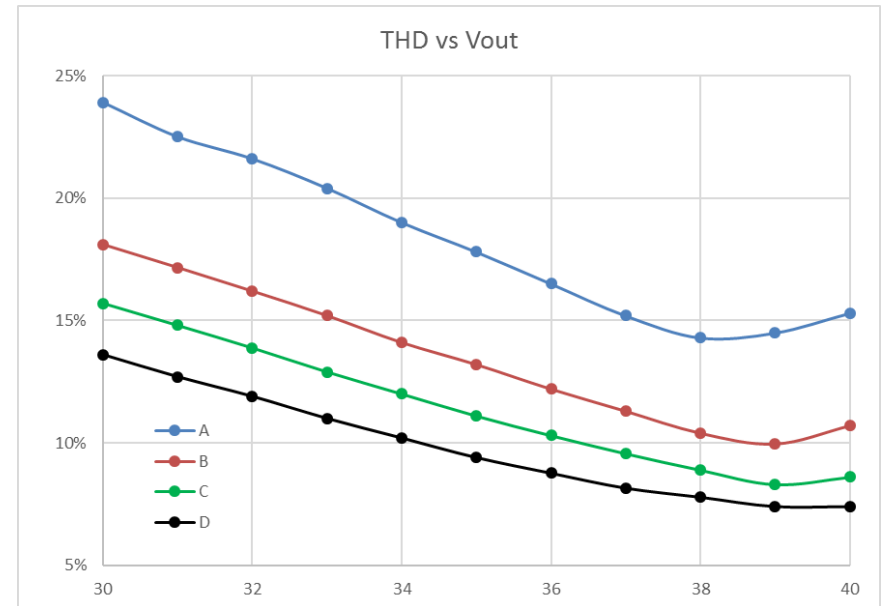
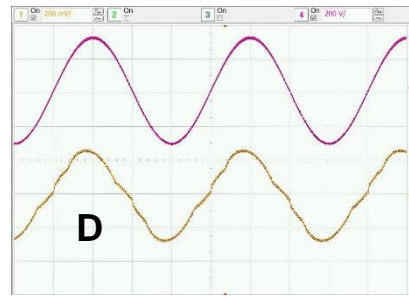
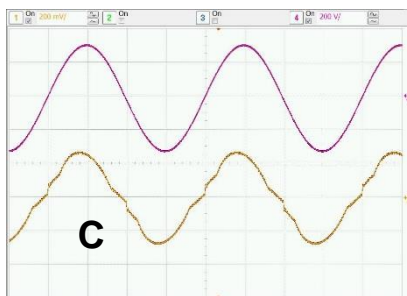
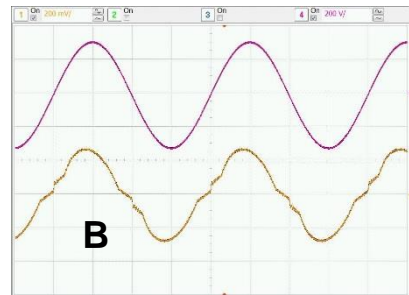
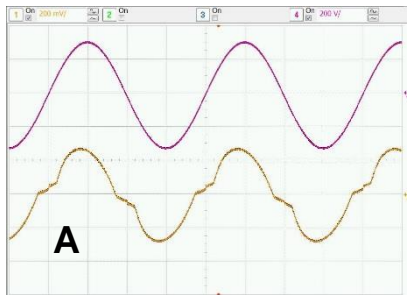

AC input current @ 230VAC, 36V

Modify output current

Only need to change boost capacitor & CS resistor to change output current from 1000mA to 700mA

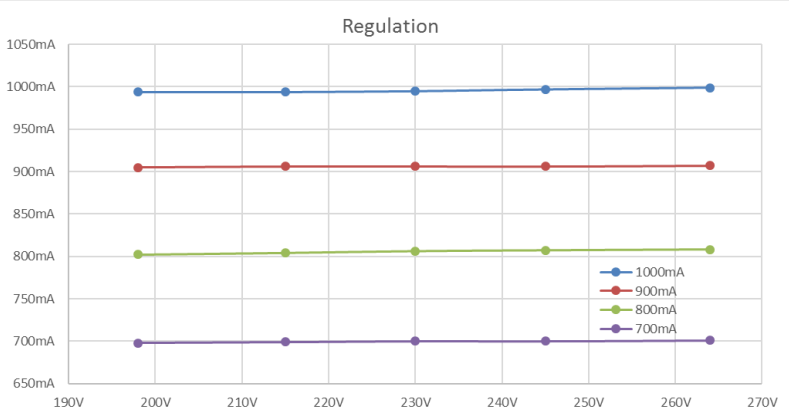
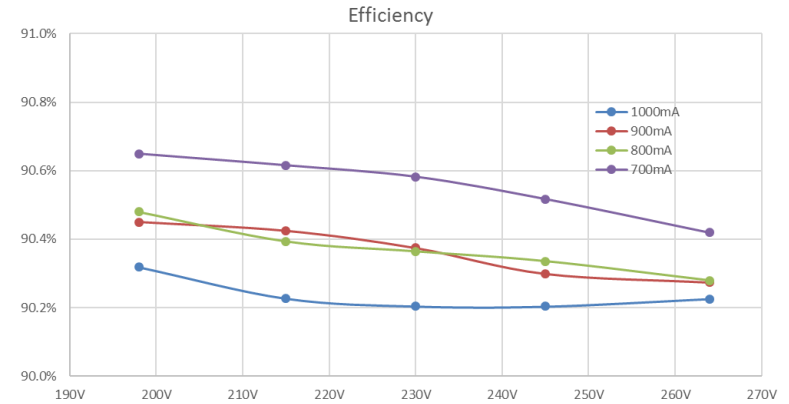
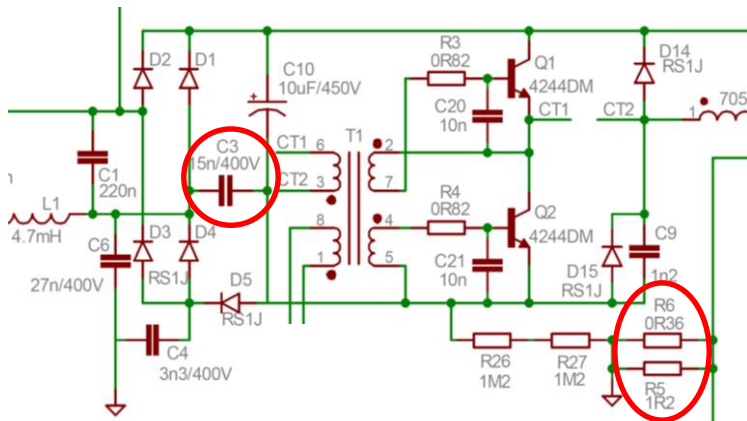

Design current	Changes		THD @ 264V & 36V	Efficiency @ 230V & 36V	Output range for good Harmonic	VHT @ 32V & 264VAC	Remarks
	C3	R5&6					
1000mA	15n	0R36 & 1R3	16.5%	90.2%	30 - 39V	400.7V	Original driver
900mA	12n	0R36 & 2R2	15.7%	90.4%	29 - 41V	405.6V	Efficiency rises as power reduces
800mA	10n	0R36 & 10R	17.0%	90.4%	30 - 41V	403.6V	Can reduce C10 to 8.2uF
700mA	8n2	0R47 & 2R7	18.9%	90.6%	31 - 40V	398.2V	Can also change L2 to EE16/10 & Q1,2 to TO92

Upgrades – Better EMI



For improved EMI margin at 150kHz to 5MHz, add an EF12.6 CM inductor

Conducted EMI with LED earthed and Driver on an earthed groundplane (Worst Case)

Conducted 9k~30MHz

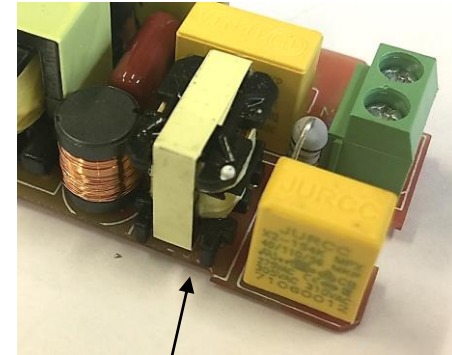
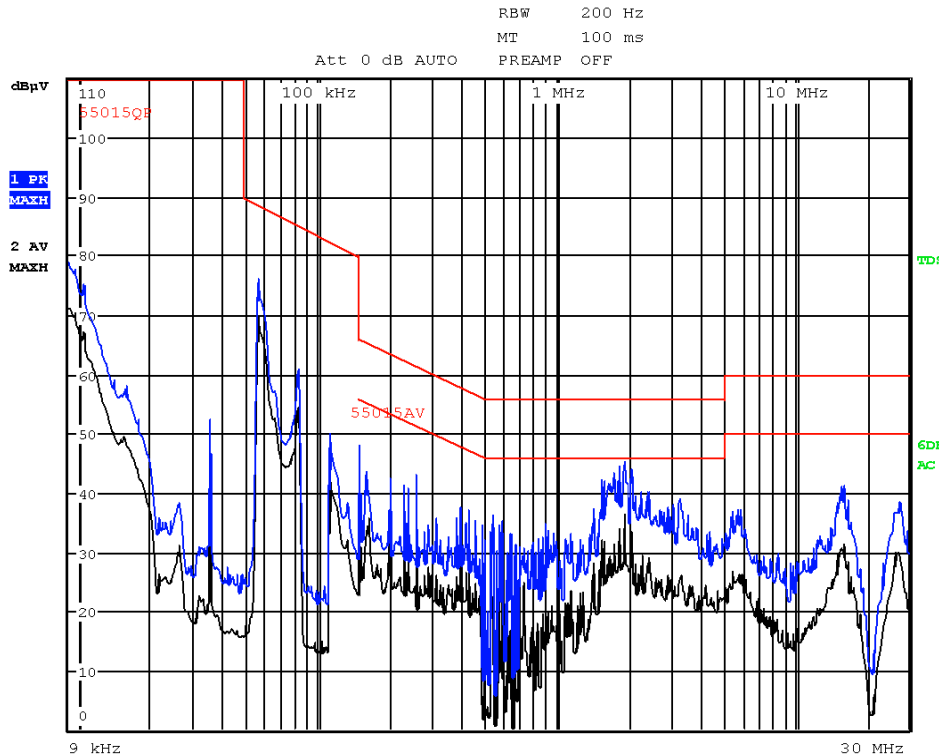

Remove Links & Fit 30mH CM choke EF12.6

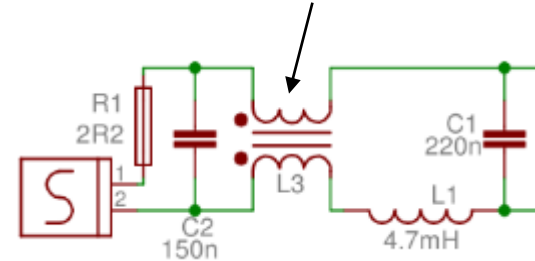

Upgrades – Lower flicker



- Change output cap(C11) to 330uF and Vdd cap(C18) to 2.2uF, Pk-Pk flicker reduces by 40%, single startup.
- Change output cap(C11) to 680uF and Vdd cap(C18) to 2.2uF, Pk-Pk flicker reduces by 60%, twice startup.
- Increasing C18 and C11 increases time to light to 400ms

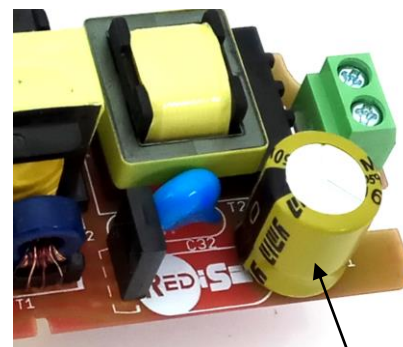

Replaced with 680uF

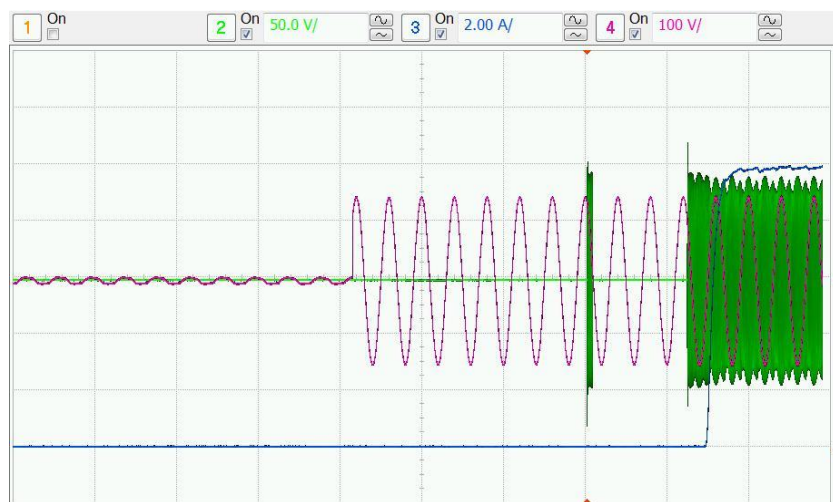

Twice startup waveform

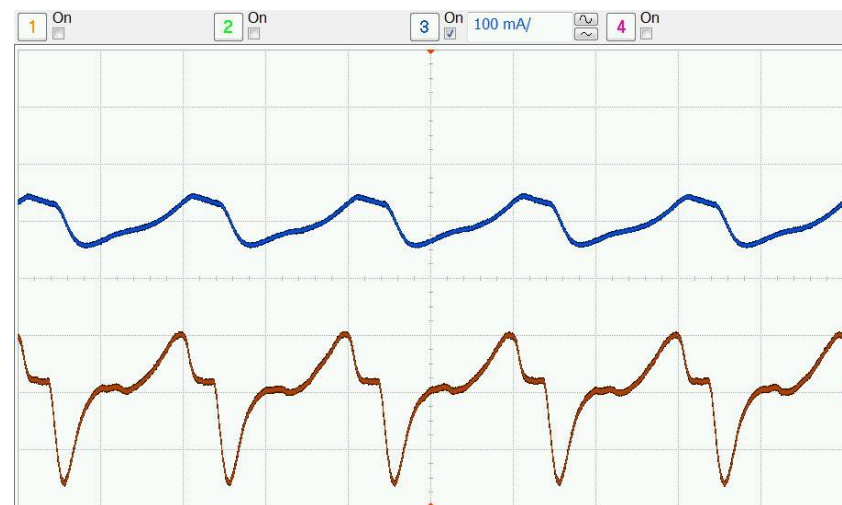

Output current ripple reduction (680uF)

Upgrades – 320VAC operation



- Consider changing bulk capacitor to 500V
- Efficiency at 320VAC = 90%
- Component temperatures after 1 hour on the bench

Thermal results	40Vdc @ 320Vac
Q1	70.0C
Q2	68.0C
Main inductor	90.0C
Transformer	82.0C
Ta	30.0C

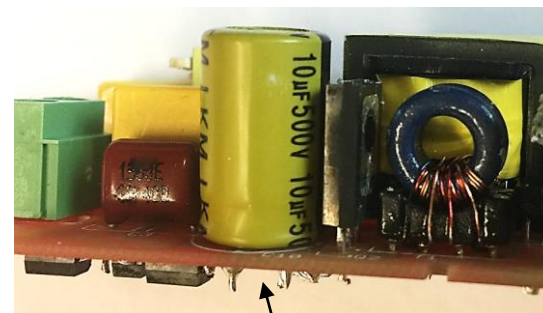

Replace E-cap with
500V type

- Because of the half-bridge configuration the converter can withstand very high input voltage
- For survival up to 460VAC and 6kV surge, see AN2114



RED2422

Low Power LED Controller for LLC converters

Features

- Advanced LED Controller IC for high efficiency low-cost LLC converters with bipolar transistors and integrated PFC
- PSR - +/-5% Primary Side Regulation of LED current and voltage with no Flicker
- 50% duty cycle, variable frequency control of resonant half-bridge
- Automatic dead-time control and capacitive mode protection
- Protection modes:
 - Overload
 - No-Load
 - Over-temperature
- Low output capacitance allows live LED connection
- Very low output current ripple – 0.5%
- Small SOT23-6 IC package



SOT23-6

Applications

- LED T8 tube drivers
- High frequency CC LED drivers up to 40W
- Pin compatible with RED2402

Order code

Part Number	Package	Packaging
RED2422AL-TR7	SOT23-6	Tape and reel

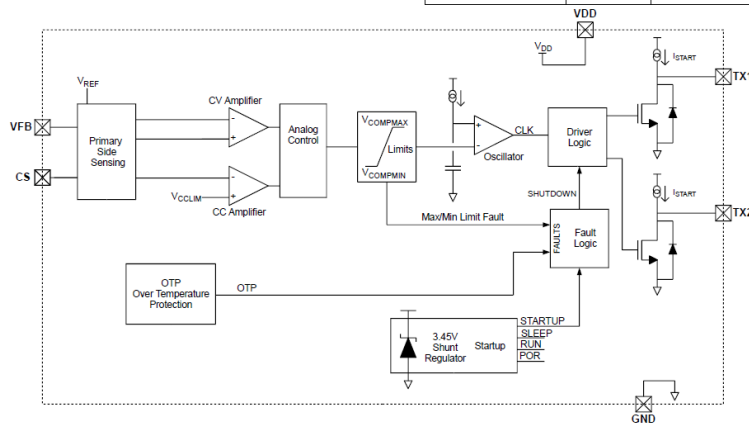

Figure 1: Block diagram



RED2422 LED LLC Controller

Device Pins

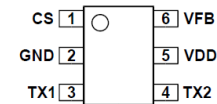
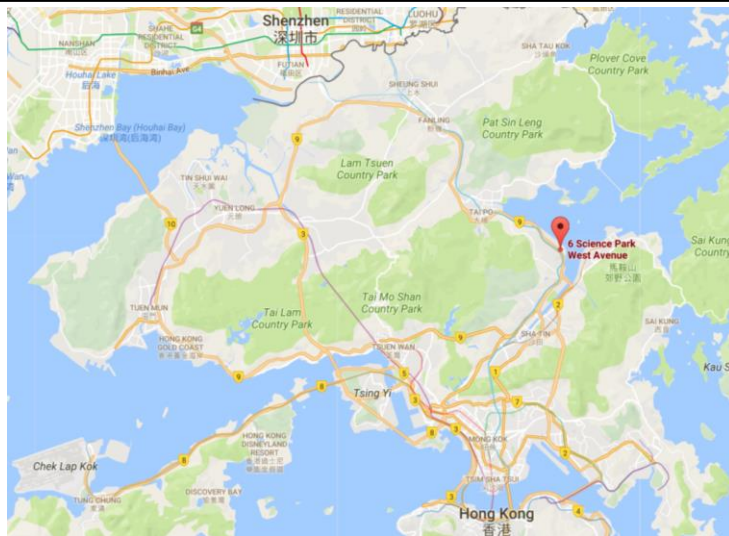

Figure 2: SOT23-6 pin connections (top view)

Pin Functions

Pin #	Name	Function
1	CS	PSR Current Sense input provides output current regulation and cycle-by-cycle over-current protection. The CS pin is connected to the half-bridge current sense resistor
2	GND	Chip ground.
3	TX1	Output to control transformer.
4	TX2	Output to control transformer.
5	VDD	IC Power Supply pin – nominally 3.45V
6	VFB	PSR Feedback input for output voltage regulation. Connect to primary sense winding.

Contact details



Hong Kong

RediSem Ltd.
301-302 IC Development Centre
No 6 Science Park West Avenue
H. K. Science & Technology Park
Shatin, New Territories
Hong Kong
tel. +852 2607 4141
fax. +852 2607 4140

Approved Distributors

China

Mobicon Electronic Trading (Shenzen) Ltd.

17F, International Trade Bldg.
Renmin South Road
Luoho District, Shenzen P.R.C.
Tel. (86-755) 8221 1737
Fax. (86-755) 8221 1774
china@mobicon.com

Honestar Shenzen Headquarter

Rm.1502, East Tower, FIYTA Tech. Bldg.
Nanshan District
Shenzhen 518057 P.R. China
Tel. 86-755-86018818
Fax. 86-755-86018808
sales@honestar.com

India

Innovatech Switching Power India Private Ltd.

55, Ground Floor, 15th Cross, 9th Main
Vyalikaval
Bangalore, Karnataka 560003
Tel. 91-80-23560288
Tel. 91-9844088331
customer.service@ispipl.com

Korea

SOONAM Co., Ltd.

697 Pangyo-Ro, (A-905, Bundang Techno Park),
Bundang-Gu, Seongnam-Si,
Kyonggi-Do, 463-816, Korea
Contact Person: Mr. Seungjib Hong
Contact Number: +82 (0)10 9001 8248
seungjib.hong@redisem.com